

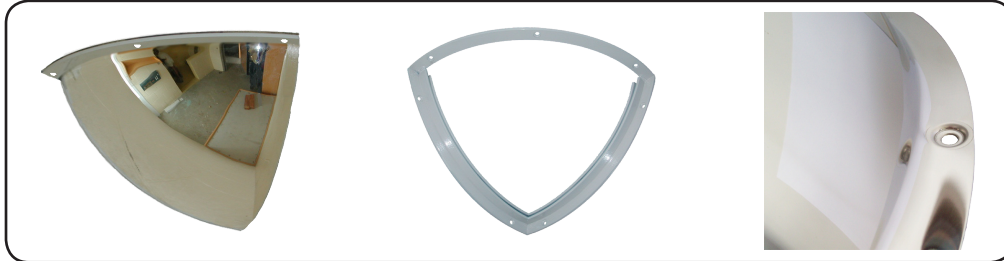

DuraVision™ Convex Mirror Installation Guide:

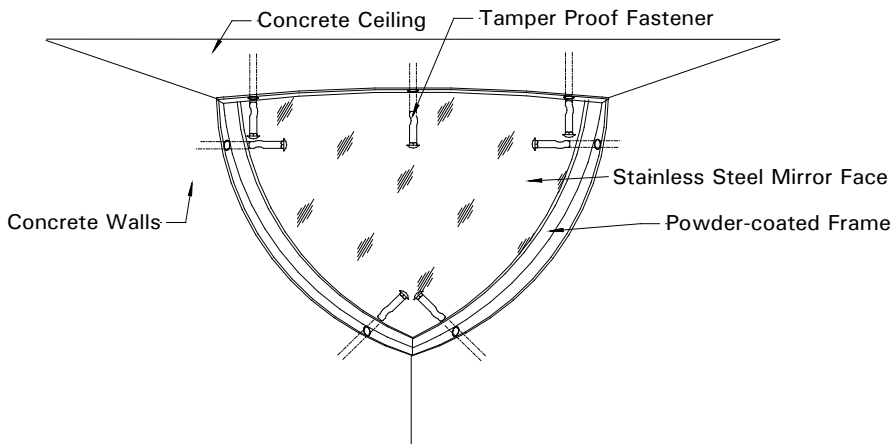

Quarter Dome Stainless Steel



NOTE: If installing with Rawl Spikes, it is recommended to use a punch. This is to eliminate damage to the mirror and powder-coated frames.

Installation Guides:

- ▶ Indoor Standard Convex Mirror
- ▶ Indoor Space Saver Convex Mirror
- ▶ Indoor Ceiling Dome Convex Mirror
- ▶ Indoor Half Dome Convex Mirror
- ▶ Indoor Quarter Dome Convex Mirror
- ▶ Outdoor Heavy Duty Convex Mirror
- ▶ Outdoor De Luxe Convex Mirror
- ▶ Outdoor Pro Series Convex Mirror
- ▶ Inspection Convex Mirrors
- ▶ Food Processing Convex Mirrors
- ▶ School Mirror Set
- ▶ [Corrections Dome With Frame](#)
- ▶ Corrections Half Dome With Frame
- ▶ Corrections Quarter Dome With Frame

Cleaning Guides:

- ▶ Acrylic Mirror
- ▶ Stainless Steel Mirror
- ▶ Polycarbonate Mirror

DuraVision™ Mirror Systems

Find out more about the great range of DuraVision Mirror Systems at our website...



www.duravision.net
www.correctionsmirror.com



DuraVision™ Convex Mirror Installation Guide:

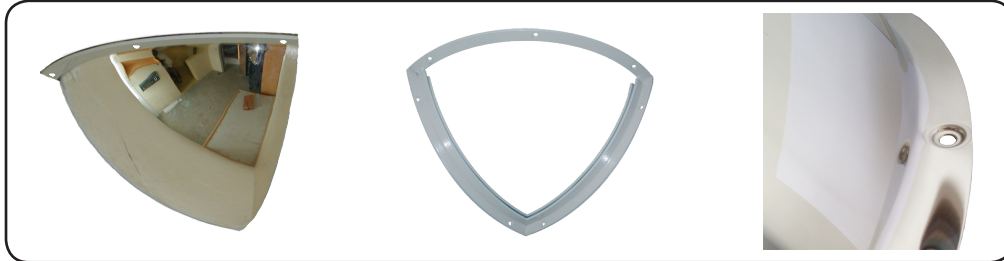

Suggested Fastening

RAWL SPIKES

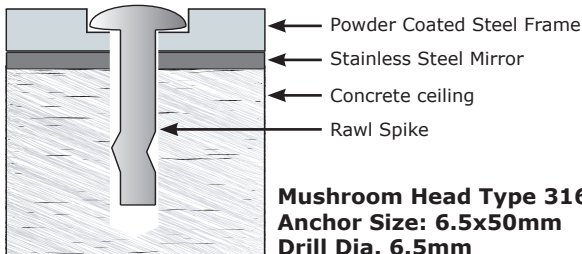

Installation: Drill a hole into the base material to a depth of at least 60mm. The tolerances of the drill bit used should meet the requirements of ISO/DIN Standard 8035. Blow the hole clean of dust and other material. Drive the Spike through the appropriate mirror face hole (and frame when used) ensuring the head is sitting firmly against the mirror or frame and recessed as shown in the above diagram.

NOTE: Care should be taken not to overdrive the Spike so as to cause damage to the powder coated surface of the frame. Finish off by applying (optional) a bead of non-pick sealant around the mirror or frame and the wall to prevent the secretion of small objects (eg razor blades etc).

DuraVision Rawl Spike Punch:

The DuraVision designed punch for inserting spikes can significantly reduce the risk of damaging the mirror face and frame during installation.



TORX SCREWS

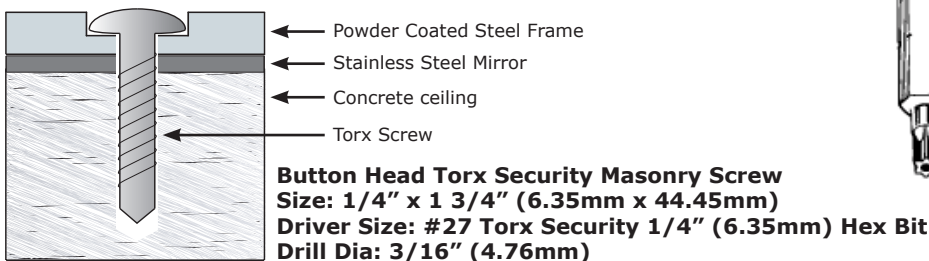

Installation: It is recommended to use a 3/16" (4.76mm) Straight Shank Tanged Bit to drill the hole. The hole must be at least 2" or 50mm overall depth and free of any debris. By using the #27, 1/4" (6.35mm) Hex Bit the special Hi-Lo thread literally taps into masonry materials. The high, sharp thread with its notched cutting edge cuts deeply and easily. The alternating low thread provides stability for fast, accurate driving. Torx Tamperproof masonry screws are the optimal fastening solution for use in concrete, brick, or hollow block.



Installation Guides:

- ▶ Indoor Standard Convex Mirror
- ▶ Indoor Space Saver Convex Mirror
- ▶ Indoor Ceiling Dome Convex Mirror
- ▶ Indoor Half Dome Convex Mirror
- ▶ Indoor Quarter Dome Convex Mirror
- ▶ Outdoor Heavy Duty Convex Mirror
- ▶ Outdoor De Luxe Convex Mirror
- ▶ Outdoor Pro Series Convex Mirror
- ▶ Inspection Convex Mirrors
- ▶ Food Processing Convex Mirrors
- ▶ School Mirror Set
- ▶ [Corrections Dome With Frame](#)
- ▶ Corrections Half Dome With Frame
- ▶ Corrections Quarter Dome With Frame

Cleaning Guides:

- ▶ Acrylic Mirror
- ▶ Stainless Steel Mirror
- ▶ Polycarbonate Mirror

DuraVision™ Mirror Systems

Find out more about the great range of DuraVision Mirror Systems at our website...



www.duravision.net
www.correctionsmirror.com